

BILL of MATERIALS

Qty.	PART #	DESCRIPTION
1	LW-866F	SMALL COOLER BASE - GRAY
2	000261	33.5" X 2" X 0.312" ALUM. BAR
2	000271	2 1/2" 3" S.S. BUTT HINGE
1	090801-00	COOLER PLUG
60"	099202	COOLER GASKET FOAM
10	164041	5/16" FLAT WASHERS
2	304210	1/4-20 X 5/16 X 3/4" SHDR BOLT
4	124012	#12 X 1-1/4" PH PN SS SCREW
4	304211	1/4-20 X 1/2" PH PN S.S. SCREW
6	304216	1/4-20 X 1-1/4" PH OV S.S. SCREW
10	304213	1/4-20 X 1" HH C/S S.S. BOLT
2	305881F	INU. MOLDED PERMANENT MOUNTS - GRAY
1	PF1005-1	SM INJECTION F/F SEAT BACK W/ RIM FOAM
1	PF1005-2	SM INJECTION F/F SEAT BTM W/ RIM FOAM

NOTE: BACK & BOTTOM ILLUSTRATIONS
DO NOT INCLUDE RIM FOAM.

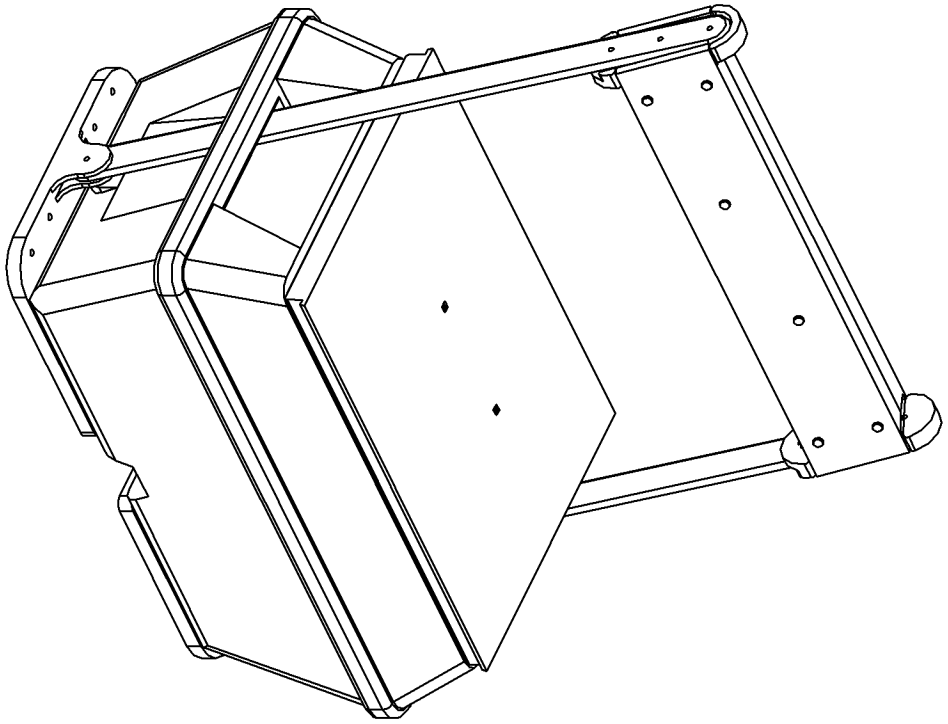

NO.	REVISION	DATE
1	REPLACE ROTO BACK & BTM W/ INJECTION.	5/20/05

THIS DRAWING AND THE ATTACHED DRAWINGS (AND THE DATA SHOWN THEREON) IS CONFIDENTIAL AND PROPRIETARY AND SHALL NOT BE USED, DISCLOSED TO OTHERS, REPRODUCED FOR ANY PURPOSE EXCEPT FOR QUOTATION TO OR ORDER BY MOELLER MARINE PRODUCTS, INC. AND/OR IT'S SUBSIDIARIES WITHOUT THEIR WRITTEN CONSENT TO THE USE OF SUCH DRAWINGS AND/OR DATA.

		DESCRIPTION	SMALL F/F COOLER, INJECTION BACK & BTM W/ RIM FOAM; NO UPHOLSTERY - ASSEMBLY
		PART #	ST2900F
MATERIAL		LINEAR POLYETHYLENE	
TOLERANCES		±1.5% UNLESS OTHERWISE NOTED	
DRAWN BY	MOELLER ENGINEERING	DATE	6/30/05

