

BILL of MATERIALS

NO. _____ REVISION _____ DATE _____

Qty.	PART #	DESCRIPTION
1	LW-861PM-SW	COOLER BASE
2	000261	33.5" X 2" X 0.312" ALUM. BAR
2	000271	2 1/2" 3" S.S. BUTT HINGE
1	090801-00	COOLER PLUG
80"	099202	COOLER GASKET FOAM
10	164041	5/16" FLAT WASHERS
4	124012	#12 X 1-1/4 PH PN SS SCREW
2	304210	1/4-20 X 5/16 X 3/4" SHDR BOLT
4	304211	1/4-20 X 1/2" PH PN S.S. SCREW
6	304216	1/4-20 X 1-1/4" PH OV S.S. SCREW
10	304213	1/4-20 X 1" HH C/S S.S. BOLT
2	305881	INJECTION MOLDED PERMANENT MOUNTS
1	PF1006-3	LARGE F/F COOLER BACK W/ FOAM & UPH (INJ)
1	PF1006-4	LARGE F/F COOLER BTM W/ FOAM & UPH (INJ)

NOTE: BACK & BOTTOM ILLUSTRATIONS
DO NOT INCLUDE RIM FOAM OR UPHOLSTERY.

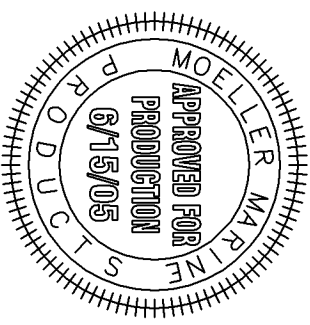
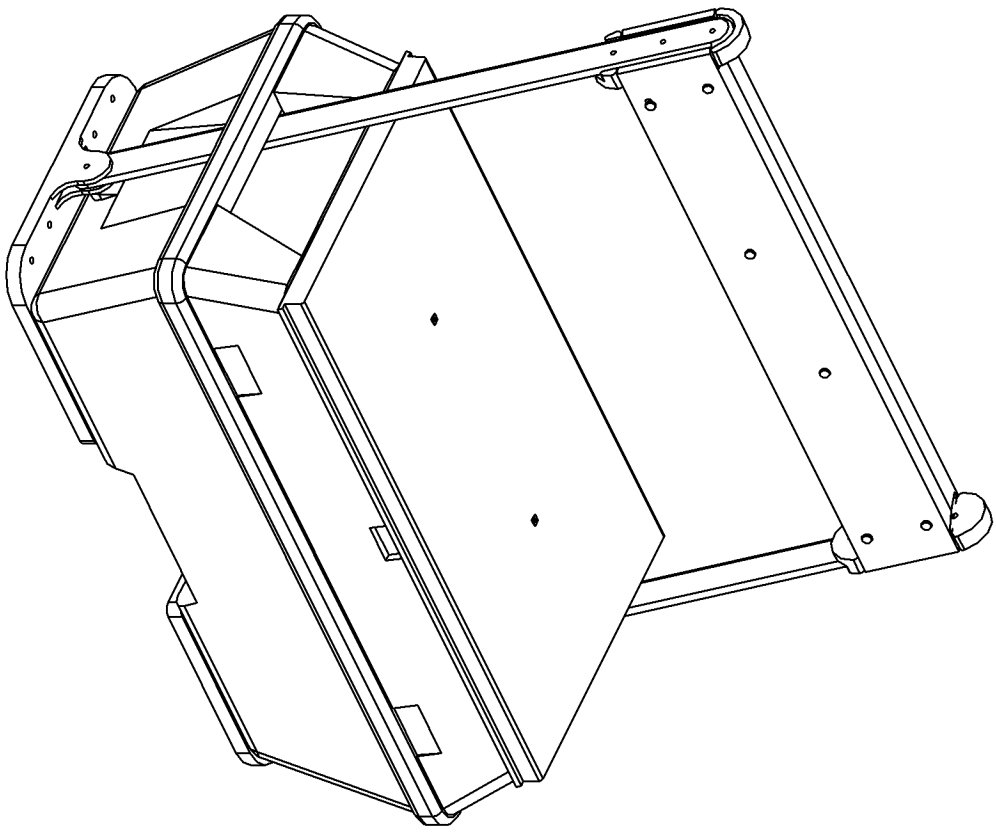

THIS DRAWING AND THE ATTACHED DRAWINGS (AND THE DATA SHOWN THEREON) IS CONFIDENTIAL AND PROPRIETARY AND SHALL NOT BE USED, DISCLOSED TO OTHERS, REPRODUCED FOR ANY PURPOSE EXCEPT FOR QUOTATION TO OR ORDER BY MOELLER MARINE PRODUCTS, INC. AND/OR IT'S SUBSIDIARIES WITHOUT THEIR WRITTEN CONSENT TO THE USE OF SUCH DRAWINGS AND/OR DATA.

	DESCRIPTION	LARGE F/F COOLER W/ FOAM & UPH / SPECKLED WHITE		
	PART #	ST2200SW	COLOR	SPECKLED WHITE
	MATERIAL	LINEAR POLYETHYLENE		
	TOLERANCES	±1.5% UNLESS OTHERWISE NOTED		
DRAWN BY	MOELLER ENGINEERING	DATE	6/15/05	